



ADVANCED CODE GROUP A GUIDE TO

Braced Wall Lines

BASED ON THE 2009 IRC

Created by STB & MER

(Commonly referred to as Wind Bracing. This guide is based on the 90 mph Wind Zone which applies throughout most of Pennsylvania)

The following FEMA graphic illustrates how winds damage buildings.

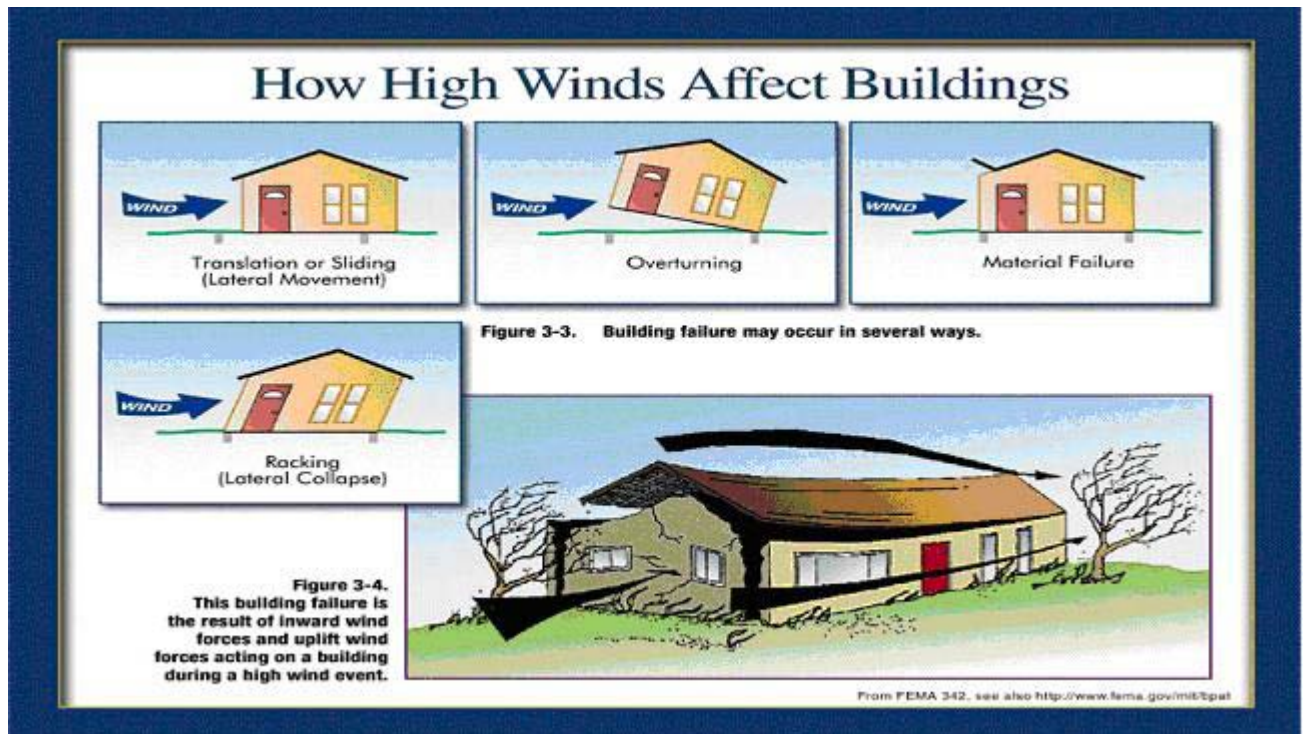

Starting in the 2003 I Codes, changes were presented to the Wind Bracing provisions of the International Residential Code (IRC). One major change was a new regulation about the design and construction of the wall panels next to large opening (garage doors). Another major change was to the bracing tables themselves.

While we may have been accustomed to the standard bracing every 25' along the exterior walls, there are now provisions for interior braced wall lines as well to support the middle of the structure. Exterior wall bracing alone may no longer be sufficient.

In the 2009 IRC, the location, design and construction requirements of exterior braced walls and interior braced walls are more in-depth and more complicated. This handout will concentrate on all of the bracing method listed in those requirements.

With the adoption of the 2009 IRC, it will be our policy that any IRC structure will be required to submit a "Braced Wall Line" plan, identifying the location of each braced wall line and the bracing method to be used. This should include the minimum amount of bracing required per Table R602.10.1.2(1), and the amount of bracing provided. (additional information is located on page 11 & 12 of this guide).

The Issue:

When the wind blows against a structure, there must be enough strength built into the walls to resist that force. Otherwise, the building will slide, lean, or fall over.

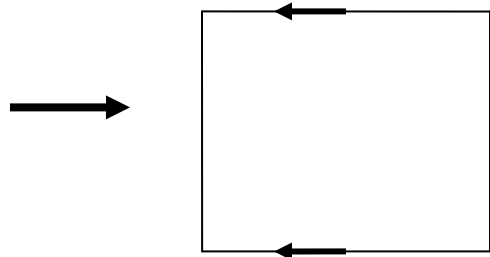

When the exterior walls are too far apart, the interior walls of the building must also be designed to resist the forces of the wind. If not, the structure has a tendency to bow in the middle. Thus, interior braced wall lines may need to be identified. When using interior braced wall lines, the required bracing length

must be increased. See Table R602.10.1.2(1), footnote e.

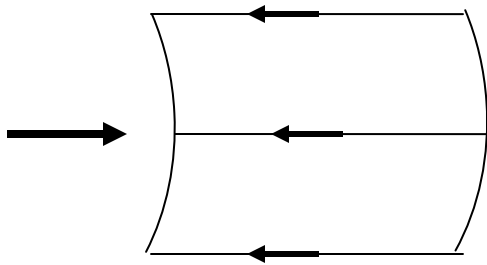

When the wind blows against the structure, if it cannot push the building off of the slab, it will try and lift the building up and roll it over. Thus, it is important to hold down the outside edges of the walls. IRC Section R403.1.6 requires exterior walls, and now requires interior braced wall panels, to be bolted to the foundation.

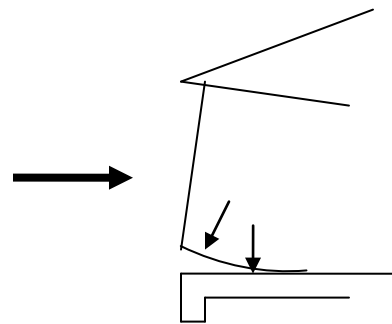

Bolts must now be installed on the interior walls at the locations identified as braced wall panels. There must be an interior grade beam under the interior braced wall line to hold the bolts. Bolts for interior braced wall panels may be drilled and need not be placed in the concrete pour. Bolts must be embedded a minimum of 7" if drilled in.

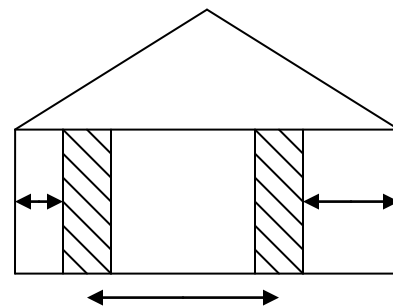

Since the wind is going to try and pick up the outside edge, it is important that the braced wall panels be close to this location. IRC Section R602.10.1.4 and Figure R602.10.1.4(2) clarify that the distance from the outside walls to the edge of the first braced wall panel, **when added together**, cannot exceed 12.5'. This will allow some doors/windows to be at the exterior edge of the braced wall line.

And, braced wall panels cannot be more than 25' on center apart along the entire wall length. See Figure 602.10.1.4(1).

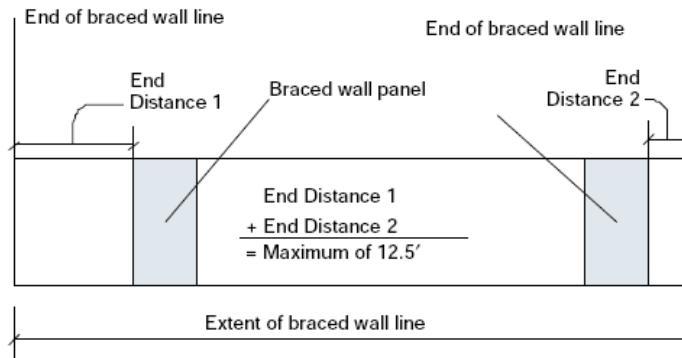

Braced wall panel shall be permitted to be located away from the end of a braced wall line, provided the total end distance from each end to the nearest braced wall panel does not exceed 12.5'. If braced wall panel is located at the end of the braced wall line, then end distance is 0'.

For SI: 1 foot = 304.8 mm.

**FIGURE R602.10.1.4(2)
BRACED WALL PANEL END DISTANCE REQUIREMENTS (SDC A, B AND C)**

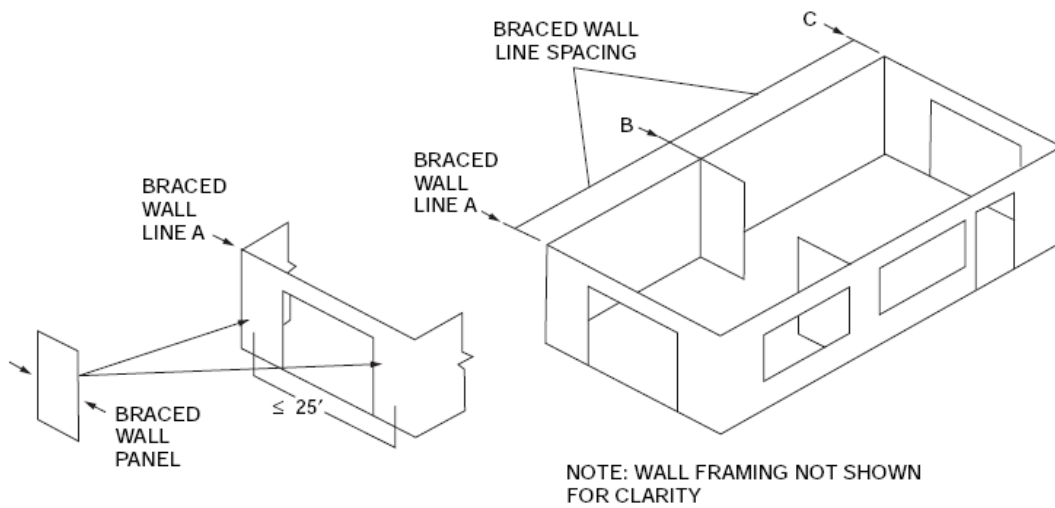

For SI: 1 foot = 304.8 mm.

**FIGURE R602.10.1.4(1)
BRACED WALL PANELS AND BRACED WALL LINES**

Connection to Framing Members

In order to connect the structure together so that the wind load is distributed throughout the building, there are requirements on how to tie a braced wall panel to floor framing/ceiling framing that is perpendicular or parallel to the wall as shown in Figures R602.10.6(1) and R602.10.6(2) below:

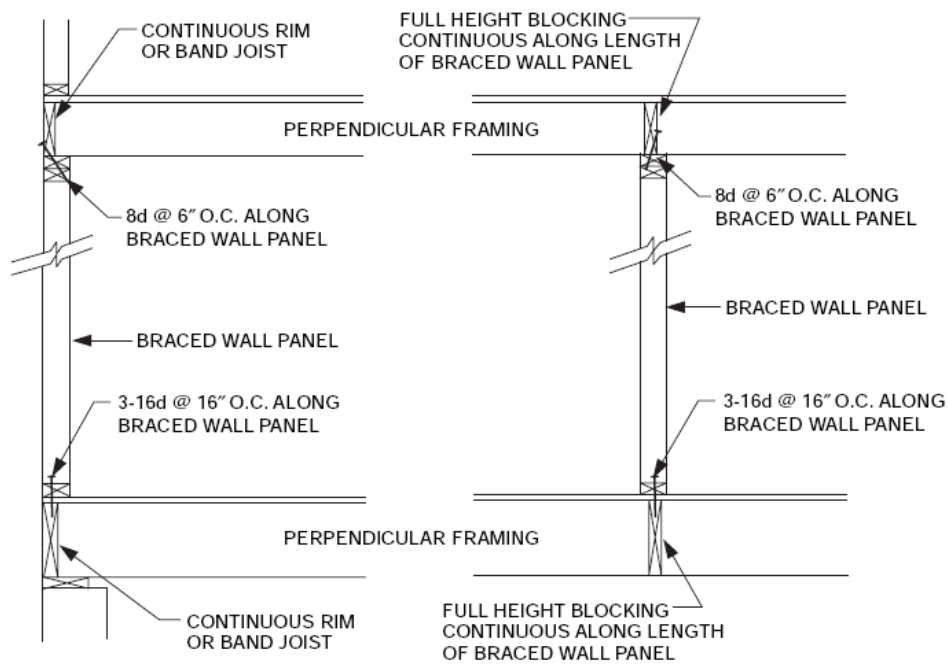

For SI: 1 inch = 25.4 mm.

FIGURE R602.10.6(1)
BRACED WALL PANEL CONNECTION WHEN PERPENDICULAR TO FLOOR/CEILING FRAMING

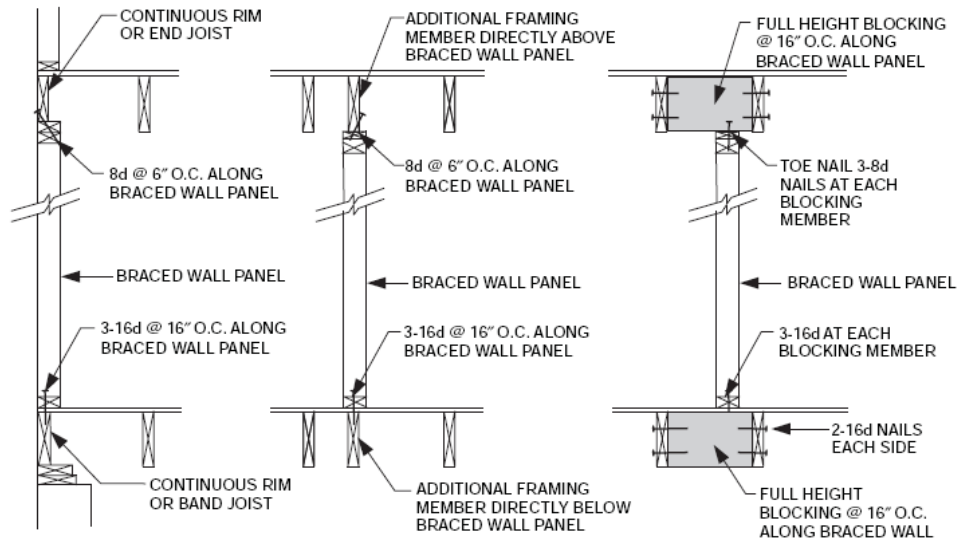

For SI: 1 inch = 25.4 mm.

FIGURE R602.10.6(2)
BRACED WALL PANEL CONNECTION WHEN PARALLEL TO FLOOR/CEILING FRAMING

In order to keep the roof framing from laying over flat at the location of the exterior braced wall panels, bracing must extend up between the joists and/or trusses, per Section R602.10.6.2, as follows:

1. Standard lateral bracing always applies throughout the structure for rafters and ceiling joists, Section R802.8.1, and for trusses, Section R802.10.3.
2. Lateral bracing at the location of the exterior wind bracing panels shall be based on the distance from the top plate to the roof deck as follows:
 - a. When less than 9.25", see normal bracing requirements under Section R802.8.1 for joists and Section R802.10.3 for trusses.
 - b. When more than 9.25" up to 15.25", see Figure R602.10.6.2(1) for rafters and see Section R802.10.3 for trusses.
 - c. When more than 15.25" but not exceeding 4' maximum, see Figure R602.10.6.2(2) and Figure R602.10.6.2(3).
3. Other than the normal bracing required by Section R802.8.1 and R802.10.3, bracing for braced wall lines is only required at each panel location. Not the entire wall length.

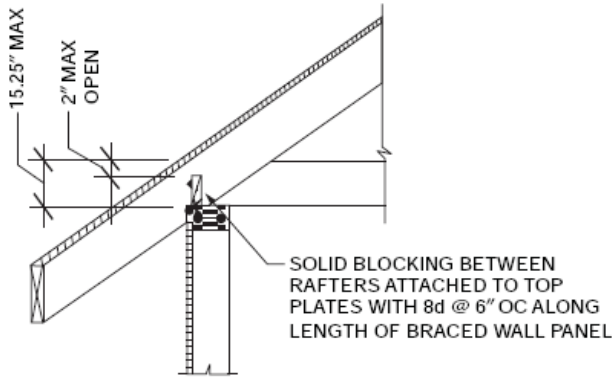

FIGURE R602.10.6.2(1)
BRACED WALL PANEL CONNECTION
TO PERPENDICULAR RAFTERS

For SI: 1 inch = 25.4 mm.

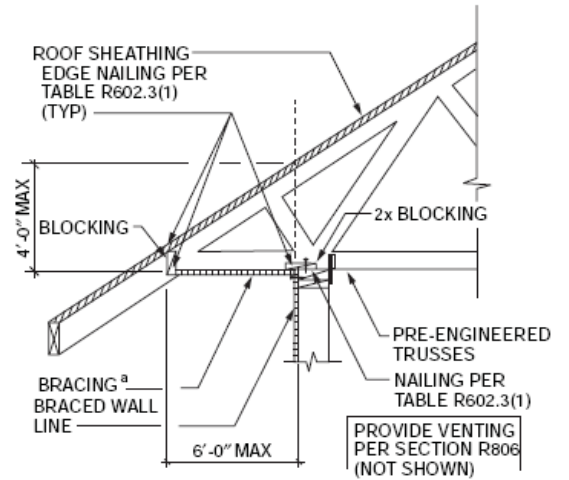

FIGURE R602.10.6.2(2)
BRACED WALL PANEL CONNECTION OPTION TO
PERPENDICULAR RAFTERS OR ROOF TRUSSES

For SI: 1 inch = 25.4 mm.

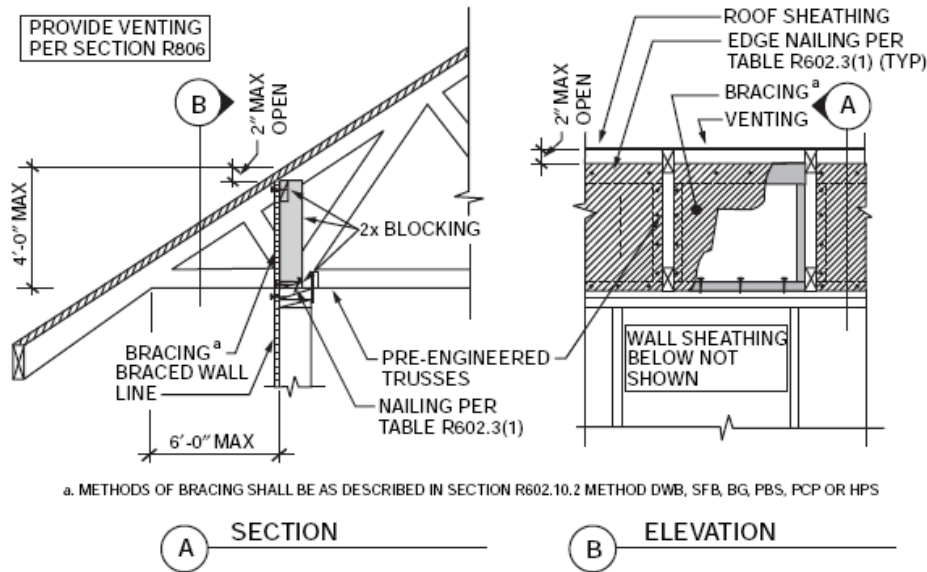

FIGURE R602.10.6.2(3)
BRACED WALL PANEL CONNECTION OPTION TO PERPENDICULAR RAFTERS OR ROOF TRUSSES

A SECTION

B ELEVATION

FIGURE R602.10.6.2(3)
BRACED WALL PANEL CONNECTION OPTION TO PERPENDICULAR RAFTERS OR ROOF TRUSSES

TABLE R602.3(1) FASTENER SCHEDULE FOR STRUCTURAL MEMBERS

| ITEM | DESCRIPTION OF BUILDING ELEMENTS | NUMBER AND TYPE OF FASTENER ^{a, b, c} | SPACING OF FASTENERS |
|--------------|---|---|---|
| Roof | | | |
| 1 | Blocking between joists or rafters to top plate, toe nail | 3-8d (2 ¹ / ₂ " x 0.113") | - |
| 2 | Ceiling joists to plate, toe nail | 3-8d (2 ¹ / ₂ " x 0.113") | - |
| 3 | Ceiling joists not attached to parallel rafter, laps over partitions, | 3-10d | - |
| 4 | Collar tie rafter, face nail or 1 ¹ / ₄ " x 20 gage ridge strap | 3-10d (3" x 0.128") | - |
| 5 | Rafter to plate, toe nail | 2-16d (3 ¹ / ₂ " x 0.135") | - |
| 6 | Roof rafters to ridge, valley or hip rafters: | 4-16d (3 ¹ / ₂ " x 0.135") 3-16d (3 ¹ / ₂ " x 0.135") | - |
| Wall | | | |
| 7 | Built-up corner studs | 10d (3" x 0.128") | 24" o.c. |
| 8 | Built-up header, two pieces with 1 ¹ / ₂ " spacer | 16d (3 ¹ / ₂ " x 0.135") | 16" o.c. along each edge |
| 9 | Continued header, two pieces | 16d (3 ¹ / ₂ " x 0.135") | 16" o.c. along each edge |
| 10 | Continuous header to stud, toe nail | 4-8d (2 ¹ / ₂ " x 0.113") | - |
| 11 | Double studs, face nail | 10d (3" x 0.128") | 24" o.c. |
| 12 | Double top plates, face nail | 10d (3" x 0.128") | 24" o.c. |
| 13 | Double top plates, minimum 48-inch offset of end joints, face nailing area | 8-16d (3 ¹ / ₂ " x 0.135") | - |
| 14 | Sole plate to joist or blocking, face nail | 16d (3 ¹ / ₂ " x 0.135") | 16" o.c. |
| 15 | Sole plate to joist or blocking at braced wall panels | 3-16d (3 ¹ / ₂ " x 0.135") | 16" o.c. |
| 16 | Stud to sole plate, toe nail | 3-8d (2 ¹ / ₂ " x 0.113") or 2-16d (3 ¹ / ₂ " x 0.135") | - |
| 17 | Top or sole plate to stud, end nail | 2-16d (3 ¹ / ₂ " x 0.135") | - |
| 18 | Top plates, laps at corners and intersections, face nail | 2-10d (3" x 0.128") | - |
| 19 | 1" brace to each stud and plate, face nail | 2-8d (2 ¹ / ₂ " x 0.113") 2 staples 1 ³ / ₄ " | - |
| 20 | 1" x 6" sheathing to each bearing, face nail | 2-8d (2 ¹ / ₂ " x 0.113") 2 staples 1 ³ / ₄ " | - |
| 21 | 1" x 8" sheathing to each bearing, face nail | 2-8d (2 ¹ / ₂ " x 0.113") 3 staples 1 ³ / ₄ " | - |
| 22 | Wider than 1" x 8" sheathing to each bearing, face nail | 3-8d (2 ¹ / ₂ " x 0.113") 4 staples 1 ³ / ₄ " | - |
| Floor | | | |
| 23 | Joist to sill or girder, toe nail | 3-8d (2 ¹ / ₂ " x 0.113") | - |
| 24 | 1" x 6" subfloor or less to each joist, face nail | 2-8d (2 ¹ / ₂ " x 0.113") 2 staples 1 ³ / ₄ " | - |
| 25 | 2" subfloor to joist or girder, blind and face nail | 2-16d (3 ¹ / ₂ " x 0.135") | - |
| 26 | Rim joist to top plate, toe nail (roof applications also) | 8d (2 ¹ / ₂ " x 0.113") | 6" o.c. |
| 27 | 2" planks (plank & beam - floor & roof) | 2-16d (3 ¹ / ₂ " x 0.135") | at each bearing |
| 28 | Built-up girders and beams, 2-inch lumber layers | 10d (3" x 0.128") | Nail each layer as follows: 32" o.c. at top and bottom Nailed. Two nails at ends and at each splice. |
| 29 | Ledger strip supporting joists or rafters | 3-16d (3 ¹ / ₂ " x 0.135") | At each joist or rafter |

(continued)

TABLE R602.3(1)-continued FASTENER SCHEDULE FOR STRUCTURAL MEMBERS

For SI: 1 inch = 25.4 mm, 1 foot = 304.8 mm, 1 mile per hour = 0.447 m/s; 1ksi = 6.895 MPa.

| ITEM | DESCRIPTION OF BUILDING MATERIALS | DESCRIPTION OF FASTENER ^{b, c, e} | SPACING OF FASTENERS | |
|--|---|--|-----------------------------|--|
| | | | Edges (inches) ⁱ | Intermediate supports ^{c, e} (inches) |
| Wood structural panels, subfloor, roof and interior wall sheathing to framing and particleboard wall sheathing to framing | | | | |
| 30 | $\frac{3}{8}$ "- $\frac{1}{2}$ " | 6d common (2" x 0.113") nail (subfloor wall) ^j 8d common (2 $\frac{1}{2}$ " x 0.131") nail (roof) | 6 | 12 ^g |
| 31 | $\frac{5}{16}$ "- $\frac{1}{2}$ " | 6d common (2" x 0.113") nail (subfloor, wall) 8d common (2 $\frac{1}{2}$ " x 0.131") nail (roof) ^f | 6 | 12 ^g |
| 32 | $\frac{19}{32}$ "- 1" | 8d common nail (2 $\frac{1}{2}$ " x 0.131") | 6 | 12 ^g |
| 33 | $1\frac{1}{8}$ "- $1\frac{1}{4}$ " | 10d common (3" x 0.148") nail or 8d (2 $\frac{1}{2}$ " x 0.131") deformed nail | 6 | 12 |
| Other wall sheathing^h | | | | |
| 34 | $\frac{1}{2}$ " structural cellulose fiberboard sheathing | $\frac{1}{2}$ " galvanized roofing nail, $\frac{7}{16}$ " crown or 1" crown staple 16 ga., $1\frac{1}{4}$ " long | 3 | 6 |
| 35 | $\frac{25}{32}$ " structural cellulose fiberboard sheathing | $1\frac{3}{4}$ " galvanized roofing nail, $\frac{7}{16}$ " crown or 1" crown staple 16 ga., $1\frac{1}{2}$ " long | 3 | 6 |
| 36 | $\frac{1}{2}$ " gypsum sheathing ^d | $1\frac{1}{2}$ " galvanized roofing nail; staple galvanized, $1\frac{1}{2}$ " long; $1\frac{1}{4}$ " screws, Type W or S | 7 | 7 |
| 37 | $\frac{5}{8}$ " gypsum sheathing ^d | $1\frac{3}{4}$ " galvanized roofing nail; staple galvanized, $1\frac{5}{8}$ " long; $1\frac{5}{8}$ " screws, Type W or S | 7 | 7 |
| Wood structural panels, combination subfloor underlayment to framing | | | | |
| 38 | $\frac{3}{4}$ " and less | 6d deformed (2" x 0.120") nail or 8d common (2 $\frac{1}{2}$ " x 0.131") nail | 6 | 12 |
| 39 | $\frac{7}{8}$ "- 1" | 8d common (2 $\frac{1}{2}$ " x 0.131") nail or 8d deformed (2 $\frac{1}{2}$ " x 0.120") nail | 6 | 12 |
| 40 | $1\frac{1}{8}$ "- $1\frac{1}{4}$ " | 10d common (3" x 0.148") nail or 8d deformed (2 $\frac{1}{2}$ " x 0.120") nail | 6 | 12 |

a. All nails are smooth-common, box or deformed shanks except where otherwise stated. Nails used for framing and sheathing connections shall have minimum average bending yield strengths as shown: 80 ksi for shank diameter of 0.192 inch (20d common nail), 90 ksi for shank diameters larger than 0.142 inch but not larger than 0.177 inch, and 100 ksi for shank diameters of 0.142 inch or less.

b. Staples are 16 gage wire and have a minimum $\frac{7}{16}$ -inch on diameter crown width.

c. Nails shall be spaced at not more than 6 inches on center at all supports where spans are 48 inches or greater.

d. Four-foot-by-8-foot or 4-foot-by-9-foot panels shall be applied vertically.

e. Spacing of fasteners not included in this table shall be based on Table R602.3(2).

f. For regions having basic wind speed of 110 mph or greater, 8d deformed (2 $\frac{1}{2}$ " x 0.120) nails shall be used for attaching plywood and wood structural panel roof sheathing to framing within minimum 48-inch distance from gable end walls, if mean roof height is more than 25 feet, up to 35 feet maximum.

g. For regions having basic wind speed of 100 mph or less, nails for attaching wood structural panel roof sheathing to gable end wall

framing shall be spaced 6 inches on center. When basic wind speed is greater than 100 mph, nails for attaching panel roof sheathing to intermediate supports shall be spaced 6 inches on center for minimum 48-inch distance from ridges, eaves and gable end walls; and 4 inches on center to gable end wall framing.

h. Gypsum sheathing shall conform to ASTM C 1396 and shall be installed in accordance with GA 253. Fiberboard sheathing shall conform to ASTM C 208.

i. Spacing of fasteners on floor sheathing panel edges applies to panel edges supported by framing members and required blocking and at all floor perimeters only. Spacing of fasteners on roof sheathing panel edges applies to panel edges supported by framing members and required blocking. Blocking of roof or floor sheathing panel edges perpendicular to the framing members need not be provided except as required by other provisions of this code. Floor perimeter shall be supported by framing members or solid blocking.

TABLE R602.3(3) REQUIREMENTS FOR WOOD STRUCTURAL PANEL WALL SHEATHING USED TO RESIST WIND PRESSURES^{a,b,c}

| MINIMUM NAIL | | MINIMUM WOOD STRUCTURAL PANEL SPAN RATING | MINIMUM NOMINAL PANEL THICKNESS (inches) | MAXIMUM WALL STUD SPACING (inches) | PANEL NAIL SPACING | | MAXIMUM WIND SPEED (mph) | | |
|--------------------------|----------------------|---|--|------------------------------------|---------------------|---------------------|--------------------------|-----|-----|
| Size | Penetration (inches) | | | | Edges (inches o.c.) | Field (inches o.c.) | Wind exposure category | | |
| | | | | | | | B | C | D |
| 6d Common(2.0" x 0.113") | 1.5 | 24/0 | 3/8 | 16 | 6 | 12 | 110 | 90 | 85 |
| 8d Common(2.5"x 0.131") | 1.75 | 24/16 | 7/16 | 16 | 6 | 12 | 130 | 110 | 105 |
| | | | | 24 | 6 | 12 | 110 | 90 | 85 |

For SI: 1 inch = 25.4 mm, 1 mile per hour = 0.447 m/s.

a. Panel strength axis parallel or perpendicular to supports. Three-ply plywood sheathing with studs spaced more than 16 inches on center shall be applied with panel strength axis perpendicular to supports.

b. Table is based on wind pressures acting toward and away from building surfaces per [Section R301.2](#). Lateral bracing requirements shall be in accordance with [Section R602.10](#).

c. Wood Structural Panels with span ratings of Wall-16 or Wall-24 shall be permitted as an alternate to panels with a 24/0 span rating. Plywood siding rated 16 oc or 24 oc shall be permitted as an alternate to panels with a 24/16 span rating. Wall-16 and Plywood siding 16 oc shall be used with studs spaced a maximum of 16 inches on center.

Identification of the braced wall line location And Plan Requirements:

Definitions:

IRC Section R202

Braced Wall Line. A straight line through the building plan that represents the location of the lateral resistance provided by the wall bracing.

Braced Wall Line, Continuously Sheathed. A *braced wall line* with structural sheathing applied to all sheathable surfaces including the areas above and below openings.

Braced Wall Panel. A full-height section of wall constructed to resist in-plane shear loads through interaction of framing members, sheathing material and anchors. The panel's length meets the requirements of its particular bracing method, and contributes toward the total amount of bracing required along its braced wall line in accordance with Section R602.10.1.

R602.10.1 Braced wall lines. The end of a braced wall line shall be considered to be either:

1. The intersection with perpendicular exterior walls or projection thereof, or;
2. The intersection with perpendicular braced wall lines.

BWL- Braced Wall Line

BWP- Braced Wall Panel

H/D- Hold Down Device

All exterior walls are braced wall lines.
If no other walls are chosen, then the following provisions apply.

The maximum distance allowed is 60' separation. That is the limit for Table R602.10.1.2(1). However, with that separation, each braced wall panel is required to have a higher construction requirement. See Figure R602.10.1.4(1).

Therefore, most tract homes, if $\leq 60'$ x $60'$, can be designed using exterior walls only. This may limit the amount and location of exterior doors and windows, but would avoid interior braced wall lines.

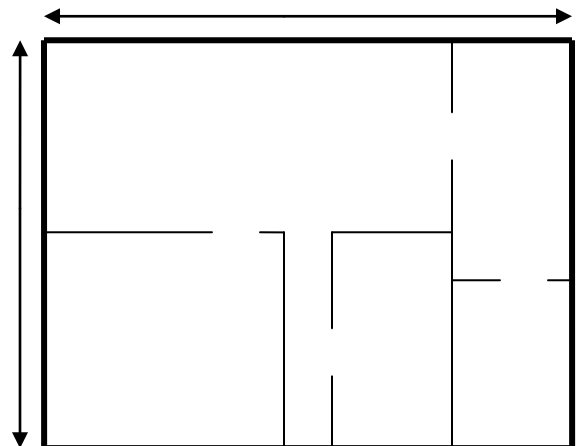

The building plans must include the location, method used, amount of bracing required, amount of bracing provided and the location of each BWP on each Braced Wall Line.

The Braced Wall Line Plan shall also contain the following:

1. A duplicate copy of all floor plans, with a highlight or overshadow marking each of the braced wall lines or marking the actual location of the braced wall panels in the new construction area.
2. When interior braced wall lines are used in the new area, a duplicate copy of the foundation plan with an identification of the interior braced wall line, and its offsets, occurring over an interior grade beam.

A worksheet must be included indicating the starting BWP amount and the required BWP amount after all applicable adjustment factors have been considered.

EXAMPLE OF PLAN REQUIREMENTS:

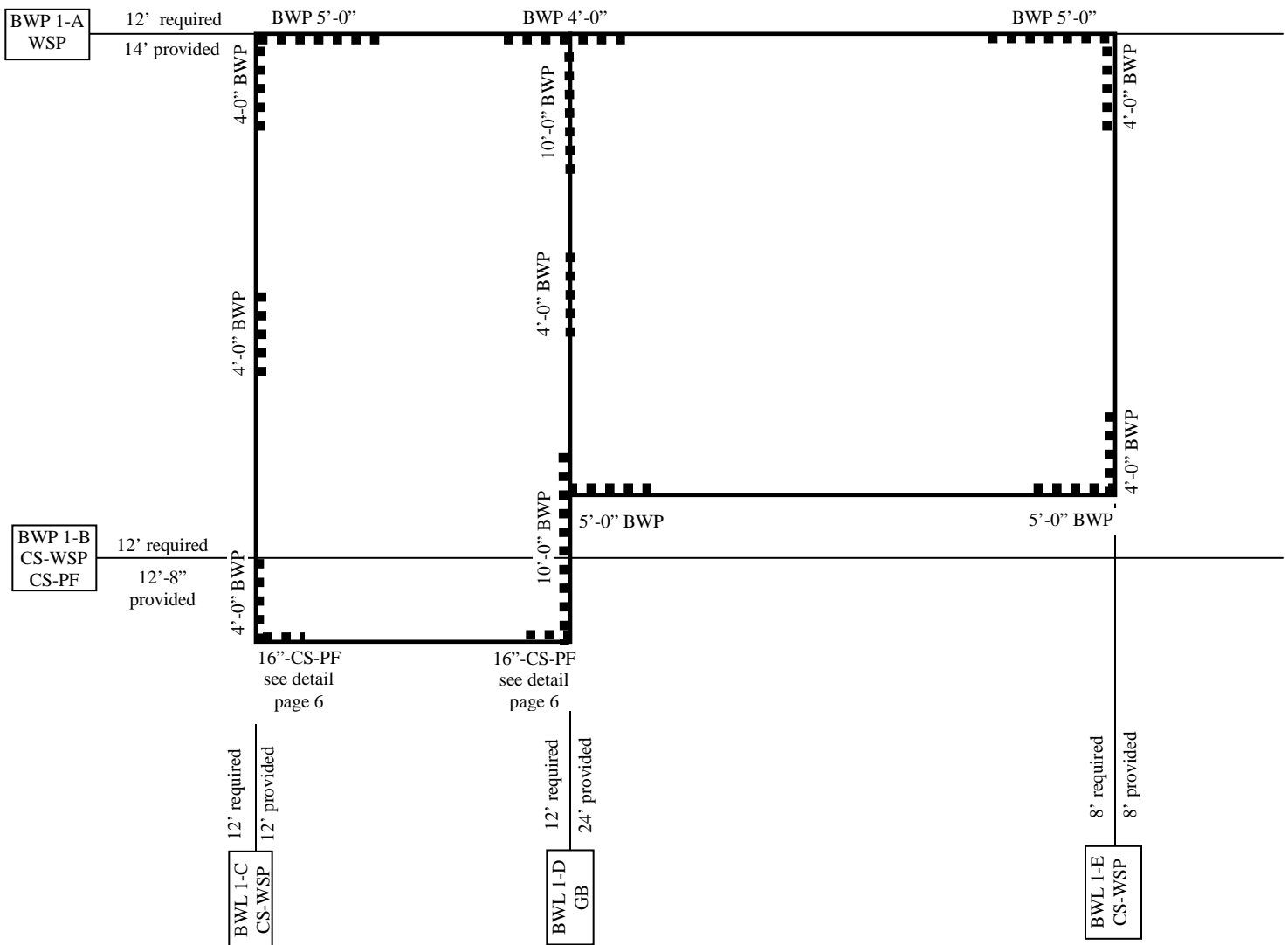

Offsets:

The braced wall line does not have to be a continuous wall. Off sets are permitted.

R602.10.1.4 Braced wall panel location. *Braced wall panels* may be offset out-of-plane up to 4 feet from the designated *braced wall line* provided that the total out-to-out- offset of *braced wall panels* in a *braced wall line* is not more than 8 feet in accordance with figures R602.10.1.4(3) and R602.10.1.4(4). All *braced wall panels* within a *braced wall line* shall be permitted to be offset from the designated *braced wall line*.

Example: Dashed arrows indicate location of braced wall lines. Interior braced wall lines must terminate at an exterior or interior braced wall line.

Interior grade beams must be installed in the foundation to hold the anchor bolts for slab on grade construction.

Off-sets cannot be any more than 4' of either side of the identified braced wall line with a total of 8' separation. Notice that none of the walls have to actually be in the location of the identified braced wall line.

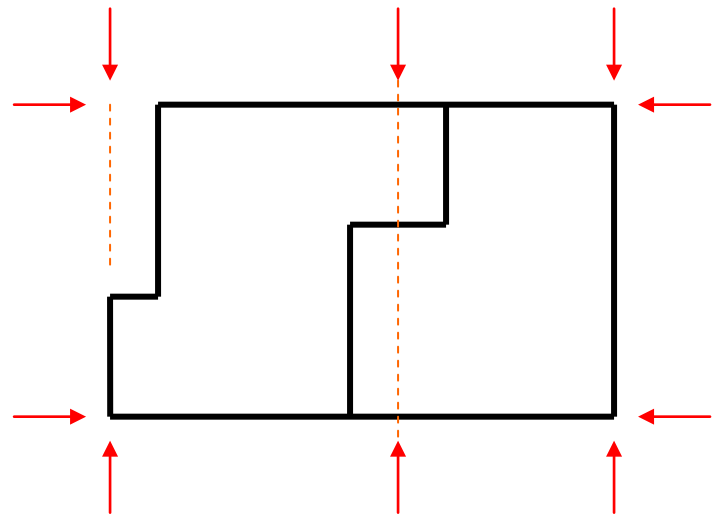

Maximum distance between BWP's

Braced wall panels must be no further apart than 25' o.c. Notice the possible locations permitted (shown as dashed lines), keeping in mind that the distance from the ends of a particular wall, when added together (except CS methods), cannot exceed 12.5'.

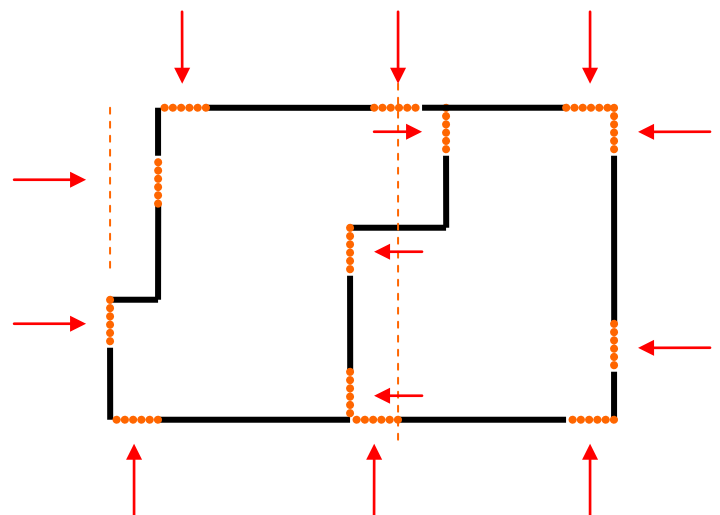

Braced Wall Panel construction methods:

The design options listed in Table R602.10.2 are available for use.

TABLE R602.10.2
INTERMITTENT BRACING METHODS







| METHOD | MATERIAL | MINIMUM THICKNESS | FIGURE | CONNECTION CRITERIA |
|--------|--|---|--|--|
| LIB | Let-in-bracing | 1 × 4 wood or approved metal straps at 45° to 60° angles for maximum 16" stud spacing |  | Wood: 2-8d nails per stud including top and bottom plate metal: per manufacturer |
| DWB | Diagonal wood boards | $\frac{3}{4}$ " (1" nominal) for maximum 24" stud spacing |  | 2-8d ($2\frac{1}{2}$ " × 0.113") nails or 2 staples, $1\frac{3}{4}$ " per stud |
| WSP | Wood structural panel (see Section R604) | $\frac{3}{8}$ " |  | For exterior sheathing see Table R602.3(3) For interior sheathing see Table R602.3(1) |
| SFB | Structural fiberboard sheathing | $\frac{1}{2}$ " or $\frac{25}{32}$ " for maximum 16" stud spacing |  | $1\frac{1}{2}$ " galvanized roofing nails or 8d common ($2\frac{1}{2}$ " × 0.131) nails at 3" spacing (panel edges) at 6" spacing (intermediate supports) |
| GB | Gypsum board | $\frac{1}{2}$ " |  | Nails or screws at 7" spacing at panel edges including top and bottom plates; for all braced wall panel locations for exterior sheathing nail or screw size, see Table R602.3(1); for interior gypsum board nail or screw size, see Table R702.3.5 |
| PBS | Particleboard sheathing (see Section R605) | $\frac{3}{8}$ " or $\frac{1}{2}$ " for maximum 16" stud spacing |  | $1\frac{1}{2}$ " galvanized roofing nails or 8d common ($2\frac{1}{2}$ " × 0.131) nails at 3" spacing (panel edges) at 6" spacing (intermediate supports) |
| PCP | Portland cement plaster | See Section R703.6 For maximum 16" stud spacing |  | $1\frac{1}{2}$ ", 11 gage, $\frac{7}{16}$ " head nails at 6" spacing or $\frac{7}{8}$ ", 16 gage staples at 6" spacing |
| HPS | Hardboard panel siding | $\frac{7}{16}$ " For maximum 16" stud spacing |  | 0.092" dia., 0.225" head nails with length to accommodate $1\frac{1}{2}$ " penetration into studs at 4" spacing (panel edges), at 8" spacing (intermediate supports) |
| ABW | Alternate braced wall | See Section R602.10.3.2 |  | See Section R602.10.3.2 |
| PFH | Intermittent portal frame | See Section R602.10.3.3 |  | See Section R602.10.3.3 |
| PFG | Intermittent portal frame at garage | See Section R602.10.3.4 |  | See Section R602.10.3.4 |

TABLE R602.10.4.1 CONTINUOUS SHEATHING METHODS

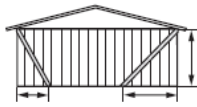
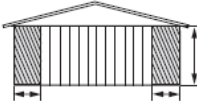
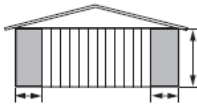
| METHOD | MATERIAL | MINIMUM THICKNESS | FIGURE | CONNECTION CRITERIA |
|--------|--|---------------------------|--|---|
| CS-WSP | Wood structural panel | 3/8" |  | 6d common (2" x 0.113") nails at 6" spacing (panel edges) and at 12" spacing (intermediate supports) or 16 ga. x 1 3/4 staples at 3" spacing (panel edges) and 6" spacing (intermediate supports) |
| CS-G | Wood structural panel adjacent to garage openings and supporting roof load only ^{a,b} | 3/8" |  | See Method CS-WSP |
| CS-PF | Continuous portal frame | See Section R602.10.4.1.1 |  | See Section R602.10.4.1.1 |

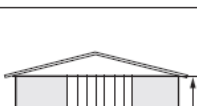
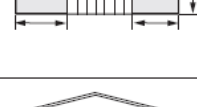
Braced Wall Panel construction requirements:

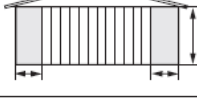
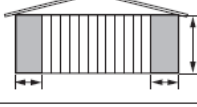
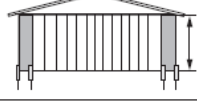
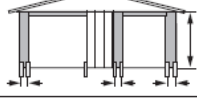
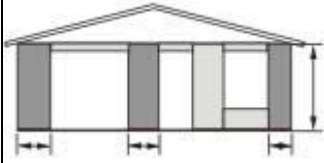
Braced Wall Panels shall be full height, from bottom plate to top plate. **Any portion that is notched around windows or doors does not count as part of the panel.**

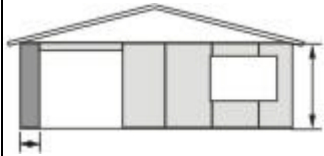
R602.10.2.1 Intermittent braced wall panel interior finish material. Intermittent *braced wall panels* shall have gypsum wall board installed on the side of the wall opposite the bracing material. Gypsum wall board shall be not less than 1/2 inch in thickness and be fastened in accordance with Table R702.3.5 for interior gypsum wall board. **(Intermittent does not include the CS methods)**

Exceptions:

1. Wall panels that are braced in accordance with Methods GB, ABW, PFG and PFH.
2. When an approved interior finish material with an in-plane shear resistance equivalent to gypsum board is installed.
3. For Methods DWB, WSP, SFB, PBS, PCP and HPS, omitting gypsum wall board is permitted provided the length of bracing in Tables R602.10.1.2(1) and R602.10.1.2(2) is multiplied by a factor of 1.5 {NOTE: Table 602.10.1.2(1) footnote "f" requires a 1.4 factor, either can be used}.

R602.10.3 Minimum length of braced panels. For Methods DWB, WSP, SFB, PBS, PCP and HPS, each *braced wall panel* shall be at least 48 inches in length, covering a minimum of three stud spaces where studs are spaced 16 inches on center and covering a minimum of two stud spaces where studs are spaced 24 inches on center. For Method GB, each *braced wall panel* shall be at least 96 inches in length where applied to one face of a *braced wall panel* and at least 48 inches where applied to both

faces. For Methods DWB, WSP, SFB, PBS, PCP and HPS, for purposes of computing the length of panel bracing required in Tables R602.10.1.2(1) and R602.10.1.2(2), the effective length of the *braced wall panel* shall be equal to the actual length of the panel. When Method GB panels are applied to only one face of a *braced wall panel*, bracing lengths required in Tables R602.10.1.2(1) and R602.10.1.2(2) for Method GB shall be doubled.

Exceptions:

1. Lengths of *braced wall panels* for continuous sheathing methods shall be in accordance with Table R602.10.4.2.
2. Lengths of Method ABW panels shall be in accordance with Section R602.10.3.2.
3. Length of Methods PFH and PFG panels shall be in accordance with Section R602.10.3.3 and R602.10.3.4 respectively.
4. For Methods DWB, WSP, SFB, PBS, PCP and HPS in Seismic Design Categories A, B, and C: Panels between 36 inches and 48 inches in length shall be permitted to count towards the required length of bracing in Tables R602.10.1.2(1) and R602.10.1.2(2), and the effective contribution shall comply with Table R602.10.3.

R602.10.3.1 Adjustment of length of braced panels. When *story height* (H), measured in feet, exceeds 10 feet, in accordance with Section R301.3, the minimum length of *braced wall panels* specified in Section R02.10.3 shall be increased by a factor H/10. See Table R602.10.3.1. Interpolation is permitted.

Total Required Length (width) of all Panels in one Braced Wall Line

Table R602.10.1.2(1) provides the necessary length that is required, adding all of the widths of each wind bracing panel along a single wall. With a minimum of 4' panel width at 25' o.c., it is possible that this accumulated individual panel width provides more width than required by the table. If 4' of panel width at 25' o.c. does not meet the minimum requirement, extra panel width will need to be added to meet the minimum.

Pennsylvania is in the 90 mph basic wind speed.

Take note that the table is limited to the following:

1. **Exposure Category B.** (See Section R301.2.1.4 for definition of exposure category. Most homes, unless alone and on a hill top, will qualify for Category B.) For a different exposure height, see the table for footnote b.
2. **30' maximum mean roof height.** For higher mean roof height, see the table for footnote b.
3. **10' maximum eave to ridge height.** For higher dimensions, see footnote c.
4. **10' maximum wall height.** For higher wall height, see adjustments necessary under Table R602.10.3.1.
5. **2 braced wall lines.** If more braced wall lines are installed, the minimum required length of bracing is increased per footnote e.
6. **Gypsum wall board,** per Section R602.10.2.1, is required on the inside of wall bracing. If not installed on the inside, see footnote f.

TABLE R602.10.1.2(1)^{a, b, c, d, e} BRACING REQUIREMENTS BASED ON WIND SPEED (as a function of braced wall line spacing)

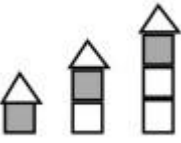
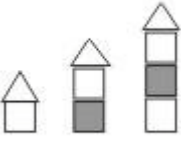
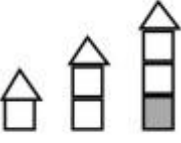
| EXPOSURE CATEGORY B, 30 FT MEAN ROOF HEIGHT, 10 FT EAVE TO RIDGE HEIGHT, 10 FT WALL HEIGHT, 2 BRACED WALL LINES | | | MINIMUM TOTAL LENGTH (feet) OF BRACED WALL PANELS REQUIRED ALONG EACH BRACED WALL LINE | | | |
|--|---|---------------------------------|--|---------------------------------------|---|----------------------|
| Basic Wind Speed (mph) | Story Location | Braced Wall Line Spacing (feet) | Method LIB ^{f, h} | Method GB (double sided) ^g | Methods DWB, WSP, SFB, PCP, HPS ^{f, i} | Continuous Sheathing |
| ≤ 90 (mph) |  | 10 | 3.5 | 3.5 | 2.0 | 2.0 |
| | | 20 | 7.0 | 7.0 | 4.0 | 3.5 |
| | | 30 | 9.5 | 9.5 | 5.5 | 5.0 |
| | | 40 | 12.5 | 12.5 | 7.5 | 6.0 |
| | | 50 | 15.5 | 15.5 | 9.0 | 7.5 |
| | | 60 | 18.5 | 18.5 | 10.5 | 9.0 |
| |  | 10 | 7.0 | 7.0 | 4.0 | 3.5 |
| | | 20 | 13.0 | 13.0 | 7.5 | 6.5 |
| | | 30 | 18.5 | 18.5 | 10.5 | 9.0 |
| | | 40 | 24.0 | 24.0 | 14.0 | 12.0 |
| | | 50 | 29.5 | 29.5 | 17.0 | 14.5 |
| | | 60 | 35.0 | 35.0 | 20.0 | 17.0 |
| |  | 10 | NP | 10.5 | 6.0 | 5.0 |
| | | 20 | NP | 19.0 | 11.0 | 9.5 |
| | | 30 | NP | 27.5 | 15.5 | 13.5 |
| | | 40 | NP | 35.5 | 20.5 | 17.5 |
| | | 50 | NP | 44.0 | 25.0 | 21.5 |
| | | 60 | NP | 52.0 | 30.0 | 25.5 |

Important Note: When using Structural fiberboard sheathing (SFB) it is important to read the manufacturer’s installation instructions, particularly for items such as stud spacing, nailing requirements and penetrations. Some fiberboard sheathing is not allowed to have any penetrations (no holes) in the section that is used for bracing.

TABLE R602.10.1.2(1)^{a, b, c, d, e}—continued
BRACING REQUIREMENTS BASED ON WIND SPEED
(as a function of braced wall line spacing)

For SI: 1 foot = 304.8 mm, 1 inch = 25.4 mm, 1 mile per hour = 0.447 m/s, 1 pound force = 4.448 N.

a. Tabulated bracing lengths are based on Wind Exposure Category B, a 30-ft mean roof height, a 10-ft eave to ridge height, a 10-ft wall height, and two braced wall lines sharing load in a given plan direction on a given story level. Methods of bracing shall be as described in Sections R602.10.2, R602.10.4 and R602.10.5. Interpolation shall be permitted.

| NUMBER OF STORIES | EXPOSURE/HEIGHT FACTORS | | |
|-------------------|-------------------------|------------|------------|
| | Exposure B | Exposure C | Exposure D |
| 1 | 1.0 | 1.2 | 1.5 |
| 2 | 1.0 | 1.3 | 1.6 |
| 3 | 1.0 | 1.4 | 1.7 |

b. For other mean roof heights and exposure categories, the required bracing length shall be multiplied by the appropriate factor from the following table:

c. For other roof-to-eave heights, the required bracing length shall be multiplied by the appropriate factor from the following table: interpolation shall be permitted.

| SUPPORT CONDITION | ROOF EAVE-TO-RIDGE HEIGHT | | | |
|-------------------|---------------------------|-------|-------|-------|
| | 5 ft or less | 10 ft | 15 ft | 20 ft |
| Roof only | 0.7 | 1.0 | 1.3 | 1.6 |
| Roof + floor | 0.85 | 1.0 | 1.15 | 1.3 |
| Roof + 2 floors | 0.9 | 1.0 | 1.1 | NP |

d. For a maximum 9-foot wall height, multiplying the table values by 0.95 shall be permitted. For a maximum 8-foot wall height, multiplying the table values by 0.90 shall be permitted. For a maximum 12-foot wall height, the table values shall be multiplied by 1.1.

e. For three or more braced wall lines in a given plan direction, the required bracing length on each braced wall line shall be multiplied by the appropriate factor from the following table:

| NUMBER OF BRACED WALL LINES | ADJUSTMENT FACTOR |
|-----------------------------|-------------------|
| 3 | 1.30 |
| 4 | 1.45 |
| ≥ 5 | 1.60 |

f. Bracing lengths are based on the application of gypsum board finish (or equivalent) applied to the inside face of a braced wall panel. When gypsum board finish (or equivalent) is not applied to the inside face of braced wall panels, the tabulated lengths shall be multiplied by the appropriate factor from the following table:

| BRACING METHOD | ADJUSTMENT FACTOR |
|--------------------------------------|-------------------|
| Method LIB | 1.8 |
| Methods DWB, WSP, SFB, PBS, PCP, HPS | 1.4 |

g. Bracing lengths for Method GB are based on the application of gypsum board on both faces of a braced wall panel. When Method GB is provided on only one side of the wall, the required bracing amounts shall be doubled. When Method GB braced wall panels installed in accordance with Section R602.10.2 are fastened at 4 inches on center at panel edges, including top and bottom plates, and are blocked at all horizontal joints, multiplying the required bracing percentage for wind loading by 0.7 shall be permitted.

h. Method LIB bracing shall have gypsum board attached to at least one side according to the Section R602.10.2 Method GB requirements.

i. Required bracing length for Methods DWB, WSP, SFB, PBS, PCP and HPS in braced wall lines located in one-story buildings and in the top story of two or three story buildings shall be permitted to be multiplied by 0.80 when an approved hold-down device with a minimum uplift design value of 800 pounds is fastened to the end studs of each braced wall panel in the braced wall line and to the foundation or framing below.

TABLE R602.10.3.1
MINIMUM LENGTH REQUIREMENTS FOR BRACED WALL PANELS

| SEISMIC DESIGN CATEGORY AND WIND SPEED | BRACING METHOD | HEIGHT OF BRACED WALL PANEL | | | | |
|---|--|-----------------------------|---------|---------|----------|----------|
| | | 8 ft | 9 ft | 10 ft | 11 ft | 12 ft |
| SDC A, B, C, D ₀ , D ₁ and D ₂ Wind speed < 110 mph | DWB, WSP, SFB, PBS, PCP, HPS and Method GB when double sided | 4' - 0" | 4' - 0" | 4' - 0" | 4' - 5" | 4' - 10" |
| | Method GB, single sided | 8' - 0" | 8' - 0" | 8' - 0" | 8' - 10" | 9' - 8" |

For SI: 1 inch = 25.4 mm, 1 foot = 304.8 mm.

5. A garage that projects more than 8' from the front wall is considered its own braced wall line. As such, a 4' panel is required every 25' o.c.

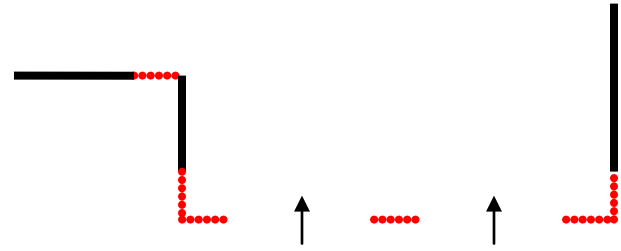

Since normal construction does not provide 4' wing walls or intermediate walls for garage openings, IRC Section R602.10.3.4 allows an alternate method around garage openings. See Figure R602.10.3.4. (These products are available from Simpson Strong Tie.) Also note the limitations listed on the following page.

Notice that the width of each wing panel is based on the height of the panel (header top) at a 4:1 ratio, with a maximum of 10', as follows:

8' height = 24" wing panel 9' height = 27" wing panel 10' height = 30" wing panel

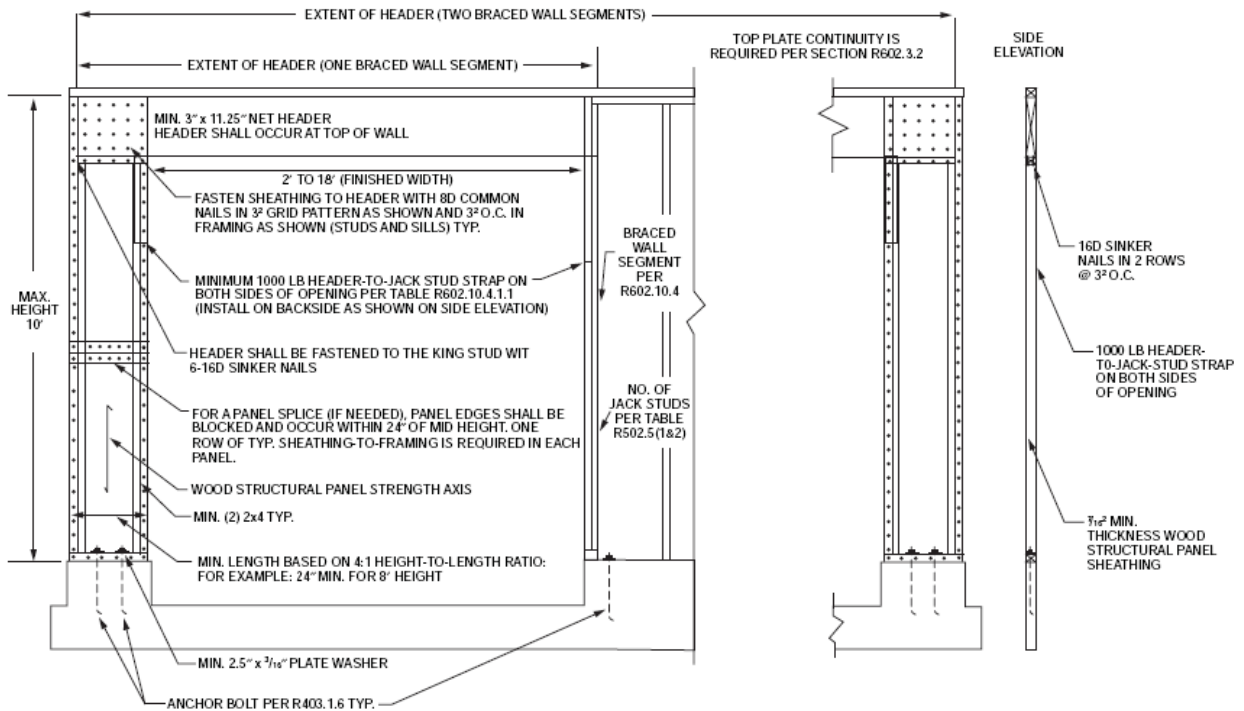

For SI: 1 inch = 25.4 mm, 1 foot = 304.8 mm, 1 pound force = 4.448 N.

FIGURE R602.10.3.4
METHOD PFG PORTAL FRAME AT GARAGE DOOR OPENINGS IN SEISMIC DESIGN CATEGORIES A, B AND C

R602.10.3.4 Method PFG (Portal Frame Garage): at garage openings in Seismic Design Categories A, B and C. Where supporting a roof or one *story* and a roof, alternate *braced wall panels* constructed in accordance with the following provisions are permitted on either side of garage door openings. For the purpose of calculating wall bracing amounts to satisfy the minimum requirements of Table R602.10.1.2(1), the length of the alternate *braced wall panel* shall be multiplied by a factor of 1.5.

1. Braced wall panel length shall be a minimum of 24 inches and braced wall panel height shall be a maximum of 10 feet.
2. Braced wall panel shall be sheathed on one face with a single layer of 7/16 –inch-minimum thickness wood structural panel sheathing attached to framing with 8d common nails at 3 inches on center in accordance with Figure R602.10.3.4.
3. The wood structural panel sheathing shall extend up over the solid sawn or glued-laminated header and shall be nailed to the header at 3 inches on center in accordance with Figure R602.10.3.4.
4. The header shall consist of a minimum of two solid sawn 2 x 12's or a 3 inches x 11.25 inch glued-laminated header. The header shall extend between the inside faces of the first full-length outer studs of each panel in accordance with Figure R602.10.3.4. The clear span of the header between the inner studs of each panel shall be not less than 6 feet and not more than 18 feet in length.
5. A strap with an uplift capacity of not less than 1,000 pounds shall fasten the header to the side of the inner studs opposite the sheathing face. Where building is located in Wind Exposure Categories C or D, the strap uplift capacity shall be in accordance with Table R602.10.4.1.1.
6. A minimum of two bolts not less than ½-inch diameter shall be installed in accordance with Section R403.1.6. A 3/16 –inch by 2 ½-inch by 2 ½-inch steel plate washer is installed between the bottom plate and the nut of each bolt.
7. Braced wall panel shall be installed directly on a foundation.
8. Where an alternate braced wall panel is located only on one side of the garage opening, the header shall be connected to a supporting jack stud on the opposite side of the garage opening with a metal strap with an uplift capacity of not less than 1,000 pounds. Where that supporting jack stud is not part of a braced wall panel assembly, another 1,000 pounds strap shall be installed to attach the supporting jack stud to the foundation.

Continuous Sheathing Method

The CS method can be used when all areas of the BWL is covered with structural sheathing, this includes the areas above and below windows and doors. No other methods can be mixed with the CS method within the same BWL. The code allows the use of CS-G and CS-PF to be included within the same BWL, to address narrow panels adjacent to garage door, windows or doors. Although the designer can choose to mix methods throughout, when a BWL is referenced as a CS-WSP and the two perpendicular walls are of a different method(except WSP placed at the corner), a H/D device will be required. In a 90 mph zone, CS panels are allowed to be installed up to 12.5' off of a corner with a H/D device. The amount of bracing required by Table R602.10.1.2(1) must be provided along a CS BWL. Each corner panel must be a minimum of 24'' unless the corner panel is adjacent to an opening then the contributing wall panel length must conform to Table R602.10.4.2. The contributing panels across the length of the BWL must also conform to Table R602.10.4.2 to contribute towards the total amount of bracing required. The CS method also requires corner stud construction to conform to Figure R602.10.4.4(1). The CS methods do not require the application of gypsum wallboard on the interior side of the wall.

Panel Joints

R602.10.8 Panel joints. All vertical joints of panel sheathing shall occur over, and be fastened to common studs. Horizontal joints in braced wall panels shall occur over, and be fastened to common block of a minimum 1 ½ inch thickness.

Exceptions:

1. Block at horizontal joints shall not be required in wall segments that are not counted a *braced wall panels*.
2. Where the bracing length provided is at least twice the minimum length required by Tables R602.10.1.2(1) and R602.10.1.2(2) blocking at horizontal joints shall not be required in *braced wall panels* constructed using Methods WSP, SFB, GB, PBS or HPS. **(NOTE: Under the 2009 IRC, CS methods are not included in this exception)**
3. When Method GB panels are installed horizontally, blocking of horizontal joints is not required.

IRC Braced Wall Line Worksheet

| | | | | | | | | |
|--|--|--|----------|----------|-----------|-----------|-----------|-----------|
| Project Address: | | | | | | | | |
| Method: | <input type="checkbox"/> LIB <input type="checkbox"/> GB <input type="checkbox"/> DWB,WSP,SFB,PCP,HPS <input type="checkbox"/> CS | | | | | | | |
| Wall Support: (check one) | <input type="checkbox"/> Roof only (one story) <input type="checkbox"/> Roof plus 1 floor (two story) <input type="checkbox"/> Roof plus 2 floors (three story) | | | | | | | |
| Braced wall line separation | Walls running left to right on the plans: _____ feet apart Walls running from top to bottom on the plans: _____ feet apart | | | | | | | |
| Braced panel height (height of top plates). Is adjustment factor per Table R602.10.1.2(1) footnote d, required? | Adjustment factor required: 1 st floor _____ feet <input type="checkbox"/> No <input type="checkbox"/> Yes Adjustment factor _____ 2 nd floor _____ feet <input type="checkbox"/> No <input type="checkbox"/> Yes Adjustment factor _____ 3 rd floor _____ feet <input type="checkbox"/> No <input type="checkbox"/> Yes Adjustment factor _____ | | | | | | | |
| Number of braced wall lines | Walls running left to right on the plans: Is adjustment factor per Table R602.10.1.2(1), footnote e required: | <input type="checkbox"/> 2 <input type="checkbox"/> 3 <input type="checkbox"/> 4 <input type="checkbox"/> ≥ 5 <input type="checkbox"/> No <input type="checkbox"/> Yes | | | | | | |
| | Walls running from top to bottom on the plans: Is adjustment factor per Table R602.10.1.2(1), footnote e required: | <input type="checkbox"/> 2 <input type="checkbox"/> 3 <input type="checkbox"/> 4 <input type="checkbox"/> ≥ 5 <input type="checkbox"/> No <input type="checkbox"/> Yes | | | | | | |
| Length of Braced Wall Panels | Walls running left to right on the plans: Walls running from top to bottom on the plans: | <table style="width: 100%; border: none;"> <tr> <td style="text-align: center;">Required</td> <td style="text-align: center;">Provided</td> </tr> <tr> <td style="text-align: center;">_____ ft.</td> <td style="text-align: center;">_____ ft.</td> </tr> <tr> <td style="text-align: center;">_____ ft.</td> <td style="text-align: center;">_____ ft.</td> </tr> </table> | Required | Provided | _____ ft. | _____ ft. | _____ ft. | _____ ft. |
| Required | Provided | | | | | | | |
| _____ ft. | _____ ft. | | | | | | | |
| _____ ft. | _____ ft. | | | | | | | |
| Is the mean roof height ≤ 30'? | <input type="checkbox"/> No <input type="checkbox"/> Yes | If No, see Table R602.10.1.2(1), footnote b. | | | | | | |
| Is the maximum eave to ridge height ≤ 10'? | <input type="checkbox"/> No <input type="checkbox"/> Yes | If No, see Table R602.10.1.2(1), footnote c. | | | | | | |
| Is gypsum wall board to be installed on the inside of all braced wall panels? | <input type="checkbox"/> No <input type="checkbox"/> Yes | If No, see Table R602.10.1.2(1), footnote f. | | | | | | |

Wall Bracing methods

LIB, DWB, WSP, SFB, GB, PBS, PCP, HPS, ABW, PFH, PFG

ABW, PFG, PFH

LIB

Max. stud spacing 16"

45 or 60 degree angle

Requires gypsum board on interior side of wall

Requires combined distance from each end not to exceed 12.5 feet.

GB

96" min. applied to one side. 48" min. applied to both sides.

Fastened 7" o.c. including top & bottom plates. Fastened 4" o.c. reduces bracing length by 0.7

Requires combined distance from each end not to exceed 12.5 feet.

DWB, WSP, SFB, PBS, PCP, HPS

48" min. panel typical or use Excpt.-Table R602.10.3 for effective lengths

Requires combined distance from each end not to exceed 12.5 feet.

Requires gypsum board on interior side of wall

ABW

Limited to two stories. Panel must be located on the first story. NOT ALLOWED on masonry stem walls.

Wall heights up to 12 feet allowed. Hold-down(s) required.

Replaces each 4 feet of BWP required.

PFH

Panel supported directly on foundation. Limited to use adjacent to a window or door opening. Requires an extended header min. 3"x11-1/4". Limited to 2-stories. Replaces each 4 feet of BWP required.

Requires a sill plate and 2 additional plates. Two 4200lb hold-down device, one 1000lb hold-down device, & one 5/8" anchor bolt embedded into the concrete.

NOT ALLOWED ON MASONRY STEM WALLS. 3" nailing pattern. 10' foot max. header height. 1000lb straps on header. 6'-18' header span. Foundation Reinforcement required.

1-STORY
16" panel permitted

1-STORY OF A 2-STORY
24" required

PFG

Panel supported directly on foundation. Limited to use adjacent to a garage door opening. Limited to supporting a roof or 1-story and a roof. 10' foot max. header height. Minimum 24" BWP 1000lb straps on header.

Requires an extended header min. 3"x11-1/4". 3" nailing pattern over header area, king stud, sill plate and outer jack. 6'-18' header span. Two 1/2" anchor bolts required with 2-1/2"x2-1/2"x3/16" washer. May require an additional 1000lb hold-down device.

Contributes 1.5 times the braced wall panel length to the required amount of bracing

CS-WSP, CS-SFB, CS-G, CS-PF

Gypsum board not required on interior

CS-WSP

All areas must be sheathed. Reduced BWP widths.

Requires returns in corners or H/D device. 12.5' offset off each corner allowed. Cannot be mixed w/intermittent methods in the same BWL. 24" min corners.

CS-SFB

All areas must be sheathed. Reduced BWP widths

Min. Lengths per Table R602.10.5.2 Requires returns in corners or H/D device. 12.5' offset off each corner allowed. Cannot be mixed w/intermittent methods in the same BWL. 32" min corners 3" o.c. nailing

CS-G

Limited to use adjacent to a garage door. Roof load only.

Can be used within the same BWL with the CS method. Maximum 10' opening height. Minimum 24" BWP. Limited to one wall of a garage only. Connection criteria same as CS-WSP

CS-PF

Limited use adjacent to an opening. 10' max header height

Limited header length of 22'. Maximum of 4 portal frames allowed in a single BWL. Minimum header size 3"x11-1/4" Max. two braced wall segments per header. 2' to 18' max header span.

Extended header required. Can be installed on raised wood floor. Requires two 1/2" anchor bolts per segment with 2x2x3/16" washers. 16" minimum width. 3" nailing pattern over header, sill king & jack studs. 1000lb H/D strap on jack-to-header connection. 670lb framing anchors at raised floor connection in lieu of sheathing overlap. Seams must be blocked. Can be installed on reinforced masonry stem walls.